

METRIC FASTENERS

Type-PT® Alternative Pan Phillips **THREAD FORMING SCREWS**

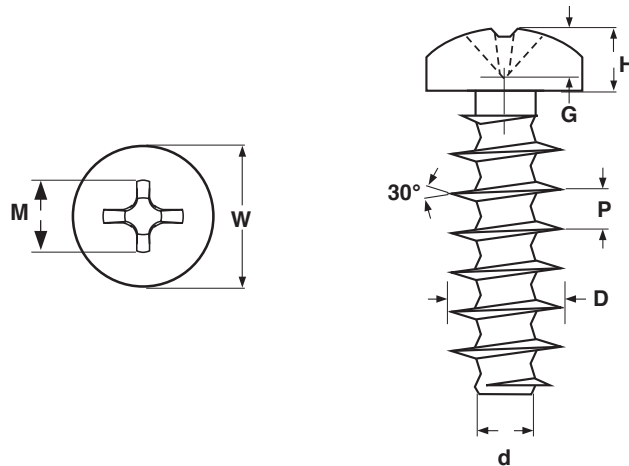

METRIC - TYPE PT®-ALTERNATIVE THREAD FORMING SCREWS, PAN PHILLIPS												
Screw Size	P	D		d	W		H		M	G		Drive Size
	Thread Dimensions				Head Dimensions				Recess Dimensions			
	Thread Pitch	External Thread Diam.		Thread Core	Diameter		Height		Diameter	Gauge Penetration		
		Max	Min	Ref	Max	Min	Max	Min	Max	Max	Min	
M1.6	0.67	1.74	1.60	0.92	2.60	2.32	1.10	0.90	1.60	0.85	0.55	0
M2	0.89	2.14	2.00	1.15	3.50	3.22	1.40	1.20	2.30	0.97	0.51	1
M2.2	0.98	2.34	2.20	1.25	3.90	3.62	1.60	1.40	2.40	1.21	0.85	1
M2.5	1.12	2.64	2.50	1.40	4.40	4.12	1.80	1.60	2.60	1.42	1.05	1
M3	1.34	3.14	3.00	1.66	5.30	5.02	2.10	1.90	2.90	1.65	1.24	1
M3.5	1.57	3.68	3.50	1.91	6.10	5.82	2.60	2.40	4.0	1.86	1.23	2
M4	1.79	4.18	4.00	2.17	7.00	6.72	2.80	2.60	4.30	2.14	1.51	2
M5	2.24	5.18	5.00	2.68	8.80	8.52	3.32	3.08	4.9	2.75	2.12	2
Tolerance on Length				3 ~ 6mm: ± 0.30 mm				7 ~ 10mm: ± 0.40 mm				
				11 ~ 30mm: ± 0.50 mm				31 ~ 80mm: ±0.65 mm				

<b>Description</b>	A spaced thread fastener with a head that has a gently rounded top, cylindrical sides and a flat bearing surface that is 90° to the screw's shank. When compared to a Plastite®-alternative thread rolling screw, the PT®-alternative threads are wider and have a sharper angle. Furthermore, the core of the shank has a reduced diameter between each consecutive set of threads. The point opposite the head is blunt.	
<b>Applications/ Advantages</b>	Designed to form its own thread in thermoplastic materials. The 30° thread angle reduces the outward expansion of the material being displaced. The recessed design of the thread root enables more material to flow into the area between threads. The depth of the thread pattern increases the fastener's load carrying properties while resisting vibrations, thus resisting loosening.	
<b>Material</b>	<p><i>Steel</i></p> <p>Diameters M3 &amp; smaller: Case-Hardened C1022 Steel Diameters M3.5 and larger: Through-hardened C1022 Steel</p>	<p><i>Stainless</i></p> <p>A2 Stainless</p>
<b>Core Hardness</b>	HV 270 - 390	
<b>Surface Hardness</b>	HV 450 min.	

Type PT® is a registered trademark of EJOT Verbindungstechnik GmbH & Co. KG. This page prints with a watermark